

# R

## REARING & MALE FEEDING

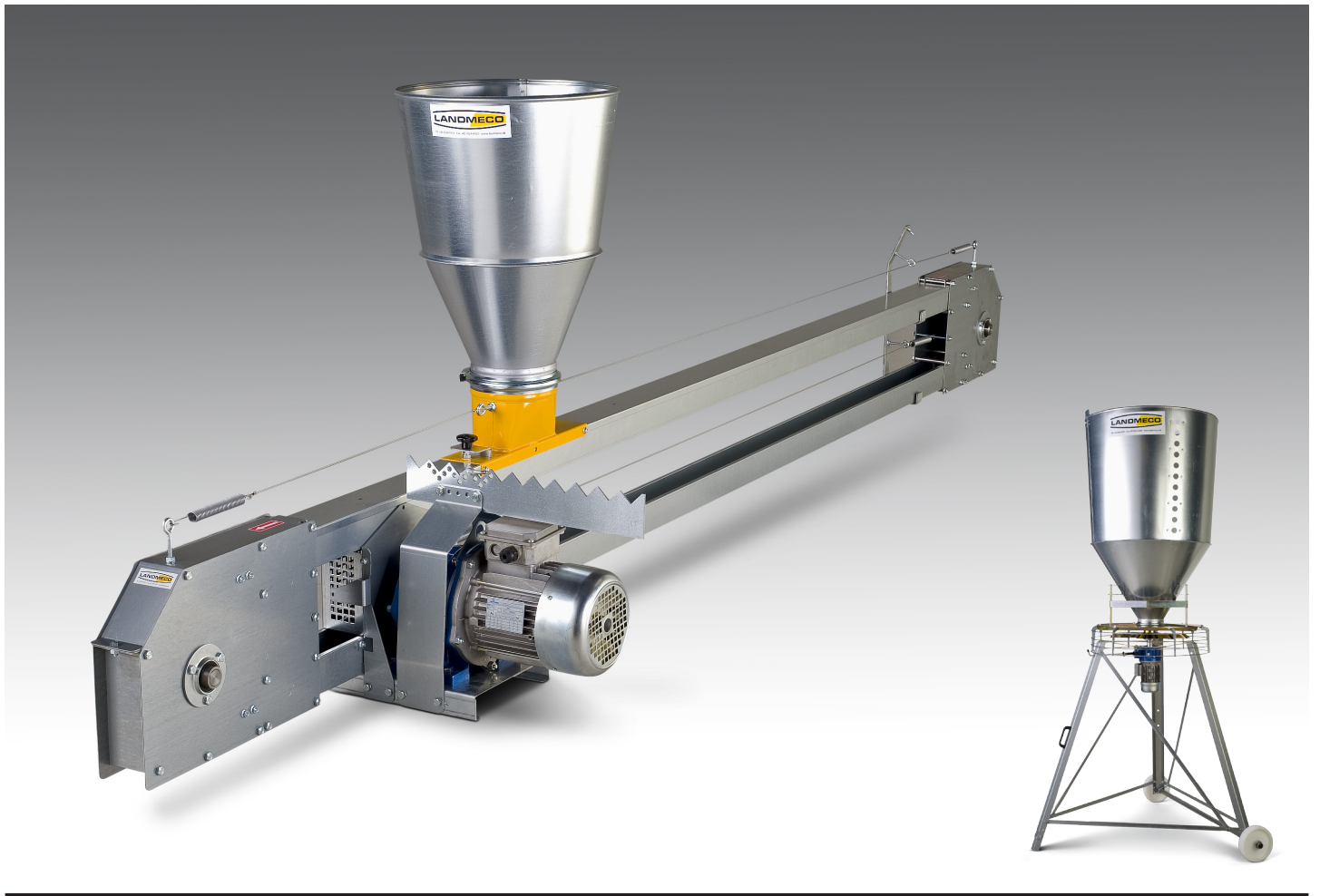

# PULLET FEEDING (0-18 WEEKS)

Spin feeders are a simple, effective and economical method of providing broiler breeder pullets (male and female) with an evenly distributed supply of feed direct on the ground. The result is birds with very uniform body weight, and only a very reduced work load for the producer.

## Function

Spin feeders with hoppers are installed along the centre of the rearing house, either suspended from the ceiling or standing on supports. All spinners start dispensing feed simultaneously. The specially developed spin head from LANDMECO ensures that feed is evenly distributed over the entire circular spread area as determined by the rotation speed.

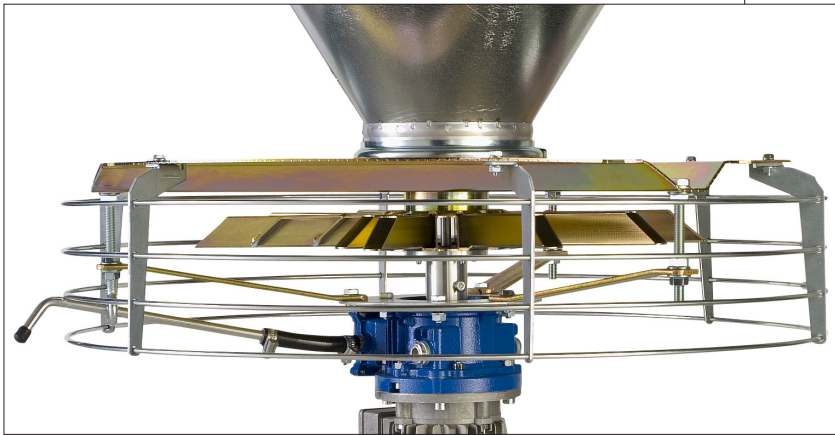

## Manual control

The Spin feeder can be operated manually by a Variator gear motor.

## Automatic controls

All spin feeders can also be operated via a central control unit, which is set according to the age of the birds:

1. The amount of feed
2. The number of feedings required
3. The duration of feeding
4. The area to be covered

# MALE FEEDING

The feeding system for males is based on the well-known, tried and tested LANDMECO chain feeding system.

## Rapid feed distribution

The direct drive and vertical return wheels allow the chain to run at very high speed. This ensures a rapid feed distribution and the simultaneous feeding of all cocks.

## Automatic controls

Male feeding is activated by a time switch on the hen feeding system so that all birds can be fed simultaneously or separately as required.

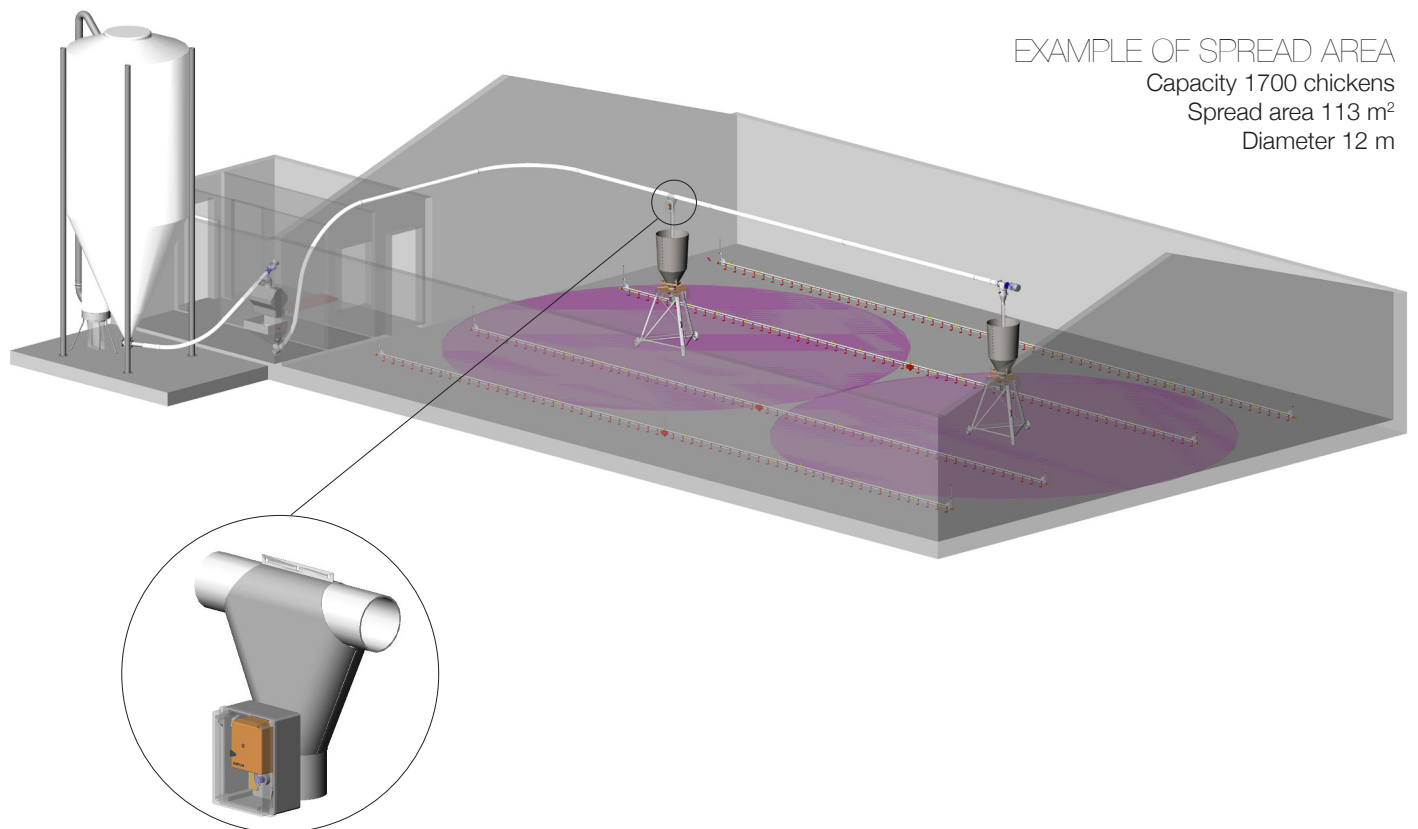

## EXAMPLE OF SPREAD AREA

Capacity 1700 chickens

Spread area 113 m<sup>2</sup>

Diameter 12 m

# TECHNICAL SPECIFICATIONS

## TECHNICAL DATA - MALE FEEDING

|                                      |                                 |
|--------------------------------------|---------------------------------|
| Gearmotor                            | 1,1 kW (3x380V)                 |
| Chain speed                          | 40 or 60 m/min ~ 1 m/sec        |
| Max. total length                    | 60 m                            |
| Min. feed quantity per meter trough  | 500 g                           |
| Max. feed quantity per meter trough  | 1500 g                          |
| No. of males per meter trough        | 13, with access from both sides |
| Weight per meter trough              | 6 kg                            |
| Min. amount of feed per meter trough | 500 g                           |

## TECHNICAL DATA - SPIN FEEDER

|                         |                            |
|-------------------------|----------------------------|
| Feed hopper             | 30-450 kg                  |
| Capacity                | Adjustable, max. 60 kg/min |
| Distribution            | Adjustable, max. 20 m      |
| Weight (without hopper) | 19 kg                      |
| Diameter                | 440 mm                     |
| Height                  | 330 mm                     |
| Motor                   | 0.55 kW (3x380 V), 900 rpm |

See also LANDMECO brochures on, for example:  
(LANDMECO retains the right to alter specifications without notice.)



PAN FEEDING



DRINKING SYSTEMS



AUGERS

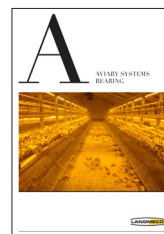

AVIARY SYSTEMS - BREEDING STOCK

AGENT

**farmtec**®

Tisová u Jistebnice 326, 391 33 Jistebnice, Tel.: +420 381 491 111, Fax: +420 381 491 112, [www.farmtec.cz](http://www.farmtec.cz), [farmtec@farmtec.cz](mailto:farmtec@farmtec.cz)